

THERMO MINIBAR 40 LT

MBT4040S Solid Door
MBT4040G Glass Door



- Advanced Environmentally Friendly Thermoelectric Cooling Technology
- Quite operation. No Fan and No vibration
- Two removable, adjustable metal shelves expand the storage space and make the fridge easy to clean
- Thermal insulation manufactured with Superior Cyclopentane
- Insulation free of CFC/HCFC
- Stocking capacity of up to 24 - 32 facings
- Fully Automatic Defrost Function
- Lower Energy Consumption than Absorption Systems
- Strong reversible door hinges, convertible to either left or right side
- Foaming Solid Door with two adjustable transparent racks
- Door is made with magnetic seals to keep it perfectly closed
- Easily Adjustable Electronic Thermostat for Ideal Temperature Control
- Soft LED Interior Light for more visibility
- Integrated Door Handles
- Free Standing or can be inserted into existing furniture- Outer Body
- Black Color | Inner Body – White Color



Electrical information

Input Voltage	220 – 240 V
Power	65 W
Input Frequency	50 – 60 Hz
Plugs	EU & BS

Product Performance

Technology	Environmental Friendly Thermoelectric Cooling Technology
Cooling	5 °C ~ 8 °C at 25 ° room temperature (Solid) 10 °C ~ 15 °C at 25 °C room temperature (Glass)
Refrigerant Amount	98 g

Additional Information

Color	Outer: Black Inner: White
Finishes	Solid Door / Glass Door
Certificates	

Shipping Details

Carton (W x D x H)	460 x 495 x 585 mm
Gross Weight	17.1 Kg / 37.69 lb
Net Weight	15.6 Kg / 34.39 lb
Packaging	01 pieces
HS Code	84182900

Drawing

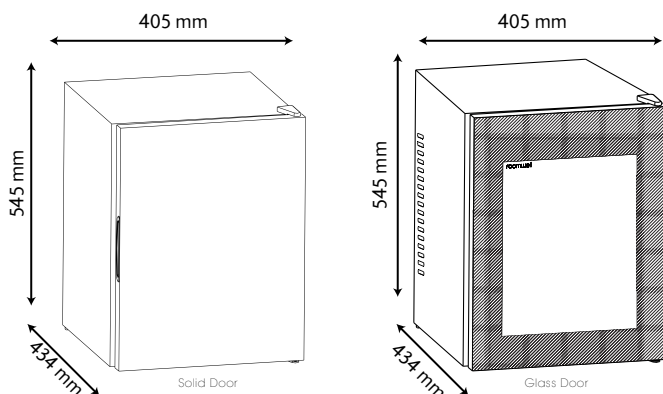

Box contents: MINIBAR, INSTALLATION GUIDE