

HI-COOL MINIBAR 30 LT

MBH4130S Solid Door
MBH4130G Glass Door



- II Generation Advanced Absorption Cooling Technology
- Noiseless Operation. No Fan and No vibration
- Two removable, adjustable tempered glass shelves with stoppers, expand the storage space and make the fridge easy to clean
- CFC/HCFC Free Thermal Insulation with ultra cooling efficiency
- Stocking capacity of up to 24 facings
- Intelligent Automatic Defrost Function
- Strong reversible door hinges, convertible to either left or right side
- Three-Layer tempered glass door structure with Argon gas-filled with good cold preservation
- Door is made with magnetic seals to keep it perfectly closed
- Concealed Thermal Regulator for convenient adjustment and preventing customer changing the setting arbitrarily
- Sensor-controlled Soft LED interior light for more visibility
- Integrated Door Handles
- Free Standing or can be inserted into existing furniture



Electrical information

Input Voltage	220 – 240 V
Power	68W
Input Frequency	50 – 60 Hz
Plugs	EU & BS

Product Performance

Technology	II Generation Advanced Absorption Cooling Technology
Cooling	05 °C ~ 10 °C at 25 °C room temperature (Solid) 10 °C ~ 15 °C at 25 °C room temperature (Glass)
Refrigerant Amount	97 g

Additional Information

Color	Outer: Black Inner: White
Finishes	Solid Door / Glass Door
Certificates	

Shipping Details

Carton (W x D x H)	462 x 497 x 548 mm
Gross Weight	18 Kg / 39.68 lb
Net Weight	15 Kg / 33.07 lb
Packaging	01 pieces
HS Code	84182900

Drawing

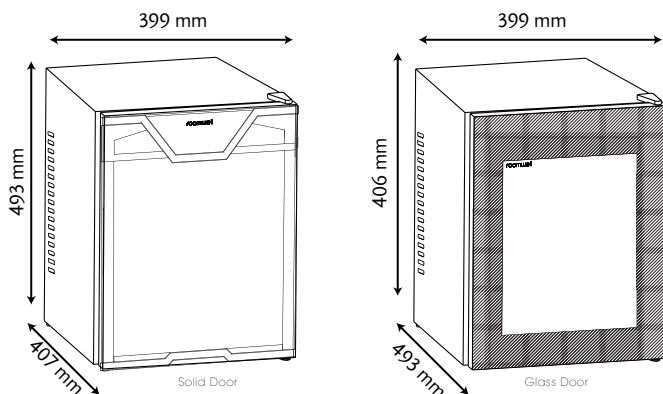

Box contents: MINIBAR, INSTALLATION GUIDE