

## HI-COOL MINIBAR 60 LT

MBH4160S Solid Door  
MBH4160G Glass Door



- II Generation Advanced Absorption Cooling Technology
- Noiseless Operation. No Fan and No vibration
- Two removable, adjustable tempered glass shelves with stoppers, expand the storage space and make the fridge easy to clean
- CFC/HCFC Free Thermal Insulation with ultra cooling efficiency
- Stocking capacity of up to 36 facings
- Intelligent Automatic Defrost Function
- Strong reversible door hinges, convertible to either left or right side
- Three-Layer tempered glass door structure with Argon gas-filled with good cold preservation
- Door is made with magnetic seals to keep it perfectly closed
- Concealed Thermal Regulator for convenient adjustment and preventing customer changing the setting arbitrarily
- Sensor-controlled Soft LED interior light for more visibility
- Integrated Door Handles
- Free Standing or can be inserted into existing furniture



### Electrical information

Input Voltage	220 – 240 V
Power	95W
Input Frequency	50 – 60 Hz
Plugs	EU & BS

### Product Performance

Technology	II Generation Advanced Absorption Cooling Technology
Cooling	05 °C ~ 10 °C at 25 °C room temperature (Solid) 10 °C ~ 15 °C at 25 °C room temperature (Glass)
Refrigerant Amount	97 g

### Additional Information

Color	Outer: Black   Inner: White
Finishes	Glass Door / Glass Door
Certificates	CE CB RoHS Compliant Intertek GS

### Shipping Details

Carton (W x D x H)	544 x 490 x 553 mm
Gross Weight	26.8 kg / 59.084 lb
Net Weight	24.5 kg / 54.014 lb
Packaging	01 pieces
HS Code	84182900

### Drawing

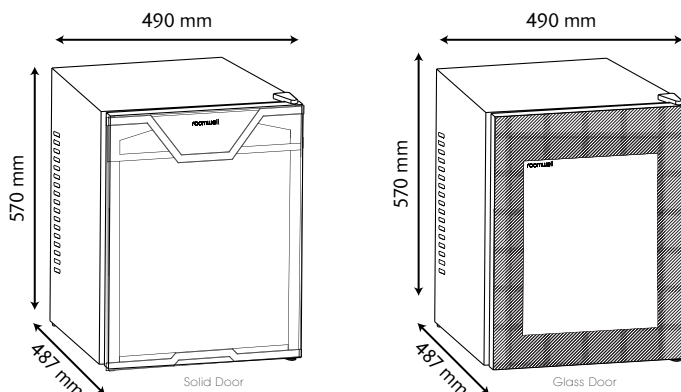

Box contents: MINIBAR, INSTALLATION GUIDE